



JDP-17F

DRILL PRESS

10000380M....230/50/1

10000380T....400/50/3

PARTS LIST



JPW Tool Group Hong Kong Limited

98 Granville Road, Tsimshatsui East, Kowloon, Hong Kong,
PRC

www.jettools.com

Импортер в РФ: ООО «ИТА Технолоджи»

105082, Москва, Переведеновский пер., д. 17

www.jettools.ru

Made in PRC / Сделано в КНР

P-10000380M/T

2022-09

Parts List For JDP-17F Drill Press

Index No.	Part No.	Description	Size	Qty.
1	10600128	Base		1
2	10700207	Column Holder		1
3	2603BBLA66	Set Screw	M10x12	1
4	12909001	Body Column		1
5	2601BBDA72	Hex Head Bolt	M10x40	4
6	10700606	Table Bracket		1
	10700606A	Table Bracket Assembly(# 6-8)		1
7	10600702	Gear		1
8	10600802	Gear Shaft		1
9	10600902	Worm		1
10A	10601009A1	Crank Handle Assy		1
12	10801201	Table Bracket		1
13	2601QBDK84	Hex Head Bolt	5/8"x1"	1
14	2701QZD506	Hex Nut	1/4*20UNC	1
15	10901402	Pin		1
16	10601601	Tilting Scale		1
17	10801701	Centering Scale		1
18	2658MZDU36	Drive Screw		2
19	10601901	Column Lock Handle	M12x35	1
20	10602001	Table Lock Handle	M10x25	1
21	10802102	Table		1
22	10602205	Rack		1
23	10702307	Rack Ring		1
24	2603BBLA37	Set Screw	M6x8	1
25	10802504G	Head		1
26	2603BBLA66	Set Screw	M10x12	2
29	10902901	Handle Shifter		1
30	10603002	Motor Bar Shifter		1
31	2601BZDAA9	Hex Head Bolt	M8x16	1
32	10703211	Motor Rod		1
33	10603301	Shifter Bolt	M10x33	2
34	10703414	Motor Base		1
35	2502NBC412	Spring Washer	1/2"	2
36	2701FBD112	Nut	M12	2
37	10603704	Hub		1
38	10603807	Feed Shaft		1
39	2536MBE611	Spring pin	ø5x16	1
43A	10604303A1	Handle Assy		1
43	10604303	Handle Bar		3
44	10604403	Gripe		3
45	10604505	Scale Ring		1
49	10604902	Coil Spring		1
50A	10605002A3	Spring Cap Assy		1
50	10605002	Spring Cap		1
51	10605115	Shaft Seat		1
52	10605202	Spring Retainer		1
53	2701QZD611	Hex Nut	1/2"	2
54	10605403	Quill Set Screw	M10x28	1
55	2701FBD110	Hex Nut	M10	1
56	100839U1	Quill		1
57	10705703	Rubber Washer		1
58	10705827	Spindle		1
59	2001ZZ6206	Ball Bearing	6206ZZ	1
61	2001ZZ6203	Ball Bearing	6203ZZ	1

Parts List For JDP-17F Drill Press

Index No.	Part No.	Description	Size	Qty.
62	10606201	Washer		1
63	10606301	Nut Lock		1
64	10606401	Spindle Nut (L.H Threads)	M17x1.0	1
65	10706508	Driving Sleeve		1
66	2001ZZ6205	Ball Bearing	6205Z	2
67	10706705	Collar		1
68	10706802	Retaining Ring		2
69	10606904	Pulley Set Nut		1
70	10807002	Spindle Pulley		1
71	21015M3B16	Drilling Arbor	MT3 x B16	1
72	2135ATQ915	Keyless Chuck	B-16	1
73	10607303	Wedge Shifter		1
74A	80082ZMT	Motor (230V, 50Hz, 1ph)		1
	80082ZMU	Motor (400V, 50Hz, 3ph)		1
	2992V55B29	Condenser 25mF (not shown)		1
76	2615BBDD28	Hex Head Bolt	M8x25	4
77	2501MBDN08	Flat Washer	M8	4
78	2701FBD113	Nut	M8	4
79	10607970	Motor Pulley		1
80	2571MNC323	Key	6x6x30	1
81	2603BBLA53	Set Screw	M8x12	1
82	2801ANHJ37	Strain Relief		2
83	10808301	CORD-CLAMP		1
84	2668BBDA39	CR. RE. PAN HD. SCREW	M6x12	1
85	2807UK026M	Power Cable (1ph)		1
	2807WU0207	Power Cable (3ph)		1
87	28992Q5N	Switch (230V, 1ph)		1
	28992Q5M	Switch (400V, 3ph)		1
88	100830D1	Switch Box		1
89	2668BBDA25	Pan Head Screw	M5x16	3
90A	10809003A1	Pulley Cover Assy		1
92	2641BBDA39	Pan Head Screw	M6x12	4
93	2620BBDB11	Pan Head Screw	M5x25	1
95	10809502	Center Pulley		1
96	2001ZZ6202	Ball Bearing	6202ZZ	1
98	10609801	Center Pulley Shaft		1
99	2572ARA290	V-Belt	A-29	1
101	2501NNVN11	Flat Washer	1/4"	4
104A	10042RAJ	Chuck Safety Guard Assy		1
106	2701QZD611	Hex Nut	1/2"	1
109	10208302	Clamp-Cord		4
110	2668BBDA32	Pan Head Screw	M5x10	4
119	2572ARA270	V-Belt	A-27	1
128	26612ZME	Tapping Screw	M6x12-25	2
140	10714001	Motor Rod		1
149	2536MBE616	Spring Pin	ø6x25	2
162	1008233Y	I.D Label		1
164	1008233X	Motor Label		1
166	1008235Q	Speed Diagram		1
167	10216714	Earth Label		1
169	11316904	JET Logo		1
298	2668BBDA22	Pan Head Screw	M5x6	2
601	2668BZDA23	Pan Head Screw	M5x8	3
602	2504MZC005	Tooth Lock Washer		2
610	261732ES	Pan Head Screw	M6x40	2
611	10661102	Seat		1

Parts List For JDP-17F Drill Press

Index No.	Part No.	Description	Size	Qty.
613	10861301	Scale Bolt		1
614	13005701	Nut	M16	2
615	13005601	Washer		1
616	2602BBLA58	Hex Socket Cap Screw	M8x35	1
617	10082Z8X	Set Ring		1
618	10661801	Circular Nut	M16x2.0	1
625	10062ZEN	Wire Box		1
634	261720XY	Hex Socket Screw		1
700	2138MBL703	Angle Wrench		1
701	2138MBL705	Angle Wrench		1
702	2138MBL706	Angle Wrench		1
814	2813DH5502	Wire Connector		1
815	2668BZDA04	Pan Head Screw	M3x20	2
822	2668BBDA28	Pan Head Screw	M5x25	4
834	10483401	Insulating B barrier		1
848	2658MZDU36	Drive Screw		2
849	10884901	Scale		1
880	2852E55518(3Ph)	Rocker Switch (FW/REV)		1
881	28532Z3L	Circuit Breaker Switch (RB2)		1
899	2641BBDA23	Pan Head Screw	M5x8	2
912	2705FBD105	Nut	M5x0.8	1
920	10892001	Tension Plate		1
922	2801ABRF04	Strain Relief		2
300	213055550A1	Vise		1
932	10042R76	Dust Guard (three)		1
933	10042R90	Fuse Holder Assy		1
934	28042R8K	Fuse		1
935	28532Z3L(1Ph)	Circuit Breaker Switch		1
936	10042R77	Dust Guard (four)		1
937	10082YYC	Dust Guard		1
500	2668BZDA04	CR.RE. Pan HD. Screw	M3x20	2
501	10292301	Retaining Clip		1
502	10287701	Limit Switch Insulation Block		1
503	2856D55B08	Limit Switch		1
504	10287601	Limit Switch Guard		1
505	2701FZD101	Hex. Nut	M3x0.5	2
506	2641BBDA23	CR. RE. Round Washer HD. Screw	M5x8	3
507	10292402	Pressing		1
508	280633Z4	Lead Wire Ass'y		1
	28062SSY(3Ph)			
509	280630RD	Lead Wire Ass'y		1
	28062Q60(3Ph)			
510	280630RH	Lead Wire Ass'y		1
	28062BF0(3Ph)			
511	28062R8G	Lead Wire Ass'y		1
	280655512D(3Ph)			
512	280655513D(3Ph)	Lead Wire Ass'y		1
513	1008357V	Plastic Sleeve		1

JDP-17F
10000380M
10000380T

~230V, 50Hz
3~400V, 50Hz

	colour of strands	Litzenfarben	couleur des cordons
BK	black	schwarz	noir
WH	white	weiß	blanc
BU	blue	blau	bleu
YE	yellow	gelb	jaune
RD	red	rot	rouge
BN	brown	braun	brun
GY	grey	grau	gris
GNYE	green-yellow	grün-gelb	vert-jaune
OG	orange	orange	orange
VT	violet	violett	violet

~230V,50Hz

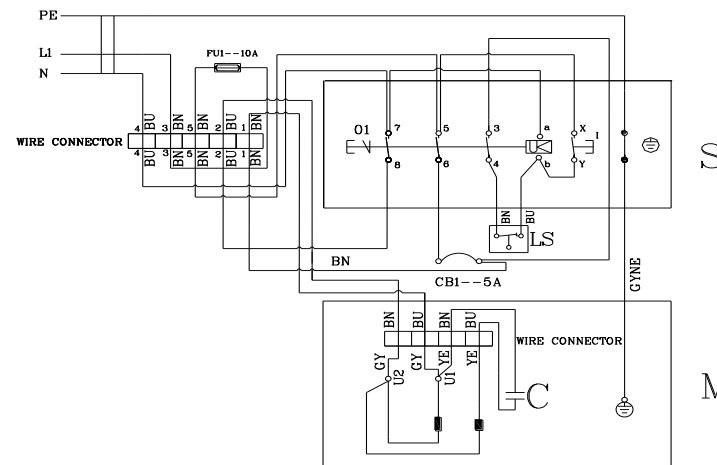

3~400V, 50Hz

	meaning of symbol	Bedeutung der Zeichen	interprétation
M	motor	Motor	moteur
S	switch	Schalter	interrupteur
C	condenser	Kondensator	condensateur
E	electronic unit	Elektronik Einheit	unité électronique
F	fuse	Sicherung	fusible
RS	reversing switch	Drehrichtungsschalter	commu. droite/gauche
CS	centrifugal switch	Fliehkraftschalter	déclencheur centrifuge
OL	overload cut-off	Überlastschuttschalter	déclencheur surcharge
LS	limit switch	Positionsendschalter	interrupteur dé fin dé course

